

Clark Hall Iron Doors

GLAZED IRON SINGLE DOOR w/ & w/out SIDELITES

INSWING/OUTSWING "NON-IMPACT"

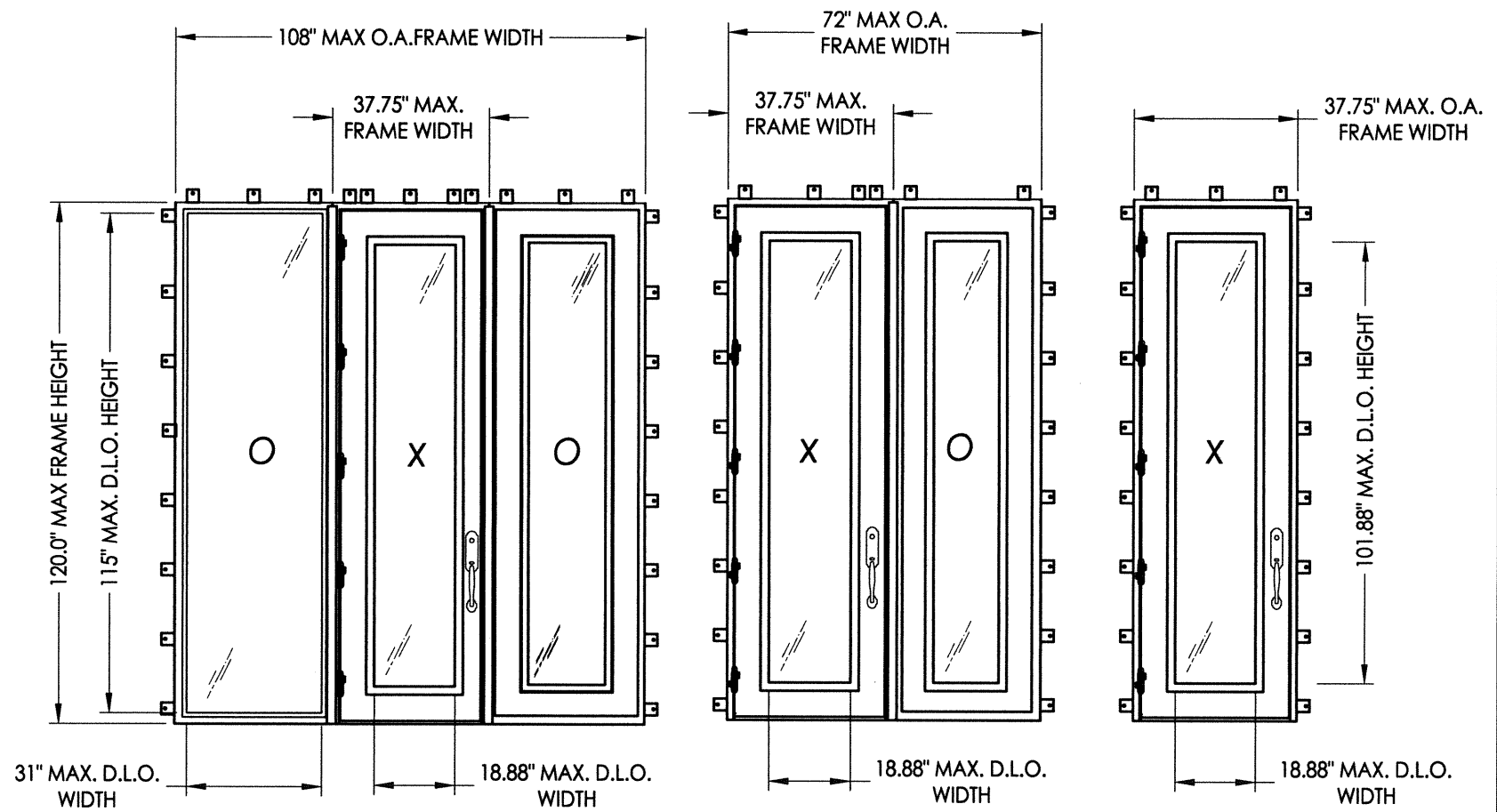

GENERAL NOTES

- This product has been evaluated and is in compliance with the 2010 Florida Building Code (FBC) structural requirements excluding the "High Velocity Hurricane Zone" (HVHZ).
- Product anchors shall be as listed and spaced as shown on details. Anchor embedment to base material shall be beyond wall dressing or stucco.
- When used in areas requiring wind borne debris protection this product is required to be protected with an impact resistant covering that complies with Section 1609.1.2 of the FBC.
- For 2x stud framing construction, anchoring of these units shall be the same as that shown for 2x buck masonry construction.
- Site conditions that deviate from the details of this drawing require further engineering analysis by a licensed engineer or registered architect.

TABLE OF CONTENTS	
SHEET#	DESCRIPTION
1	Typical elevations, design pressures, & general notes
2	Door panel details
3	Sidelite panel details
4	Glazing details
5	Elevations
6	Horizontal cross sections
7	Vertical cross sections
8	Buck anchoring
9	Frame anchoring
10	Components
11	Bill of materials & components

CONFIGURATION	OVERALL FRAME DIMENSION	DESIGN PRESSURE (PSF)			
		INSWING		OUTSWING	
		POS.	NEG.	POS.	NEG.
X	37.75" x 120.0"	+65.0	-65.0	+65.0	-65.0
OX or XO	72.0" x 120.0"	+65.0	-65.0	+65.0	-65.0
OXO	72.0" x 120.0"	+65.0	-65.0	+65.0	-65.0

Documents Prepared By:
RW BUILDING CONSULTANTS, INC.
 P.O. Box 230 Valrico FL 33595
 Phone No.: 813.659.9197
 Florida, Board of Professional Engineers
 Certificate Of Authorization No. 9813
 12.30.13
 Lyndon F. Schmidt, P.E. No. 43409

PRODUCT: CLARK HALL IRON DOORS
 PART OR ASSEMBLY:
 TYPICAL ELEVATIONS, DESIGN PRESSURES & GENERAL NOTES

NO.	DATE	BY	REVISIONS

DATE: 10/30/13
 SCALE: N.T.S.
 DWG. BY: JK
 CHK. BY: LFS
 DRAWING NO.: FL-16663.2
 SHEET 1 OF 11

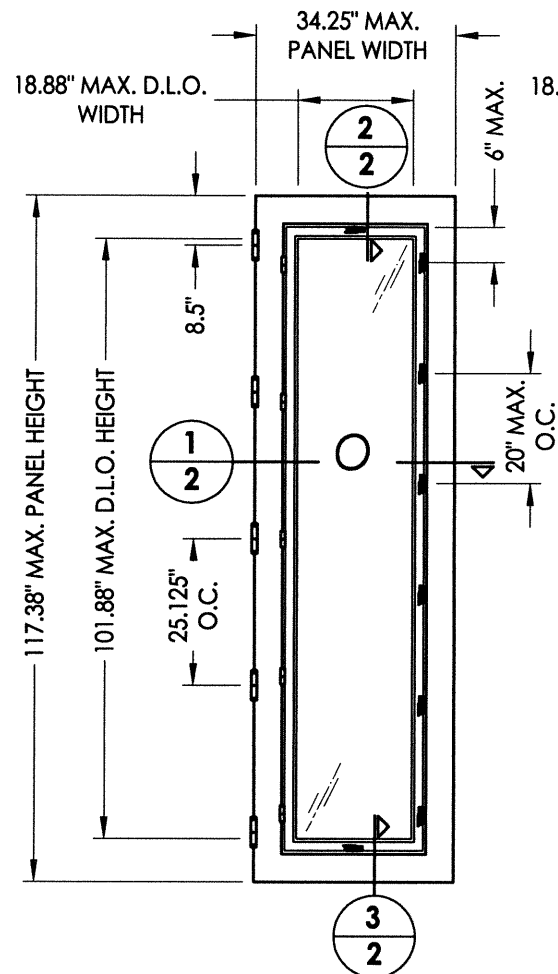

30 DOOR PANEL
w/ Operable Sash

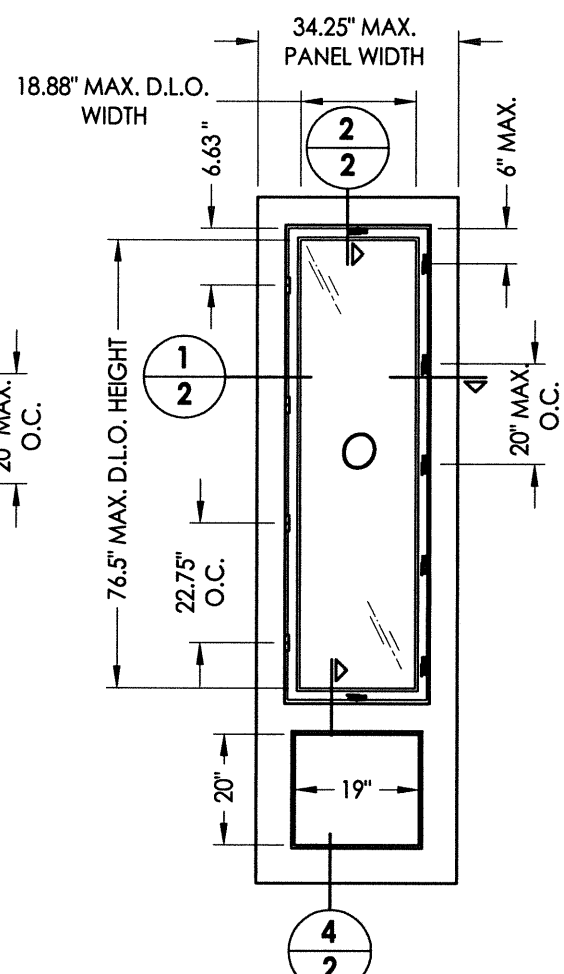

40 3/4 LITE DOOR PANEL
w/ Operable Sash

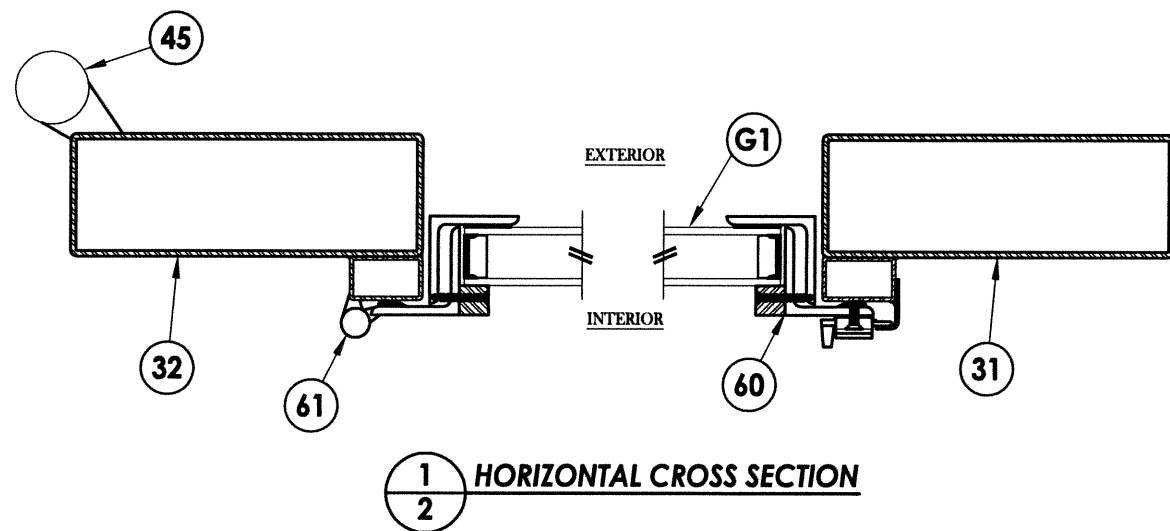

1 HORIZONTAL CROSS SECTION

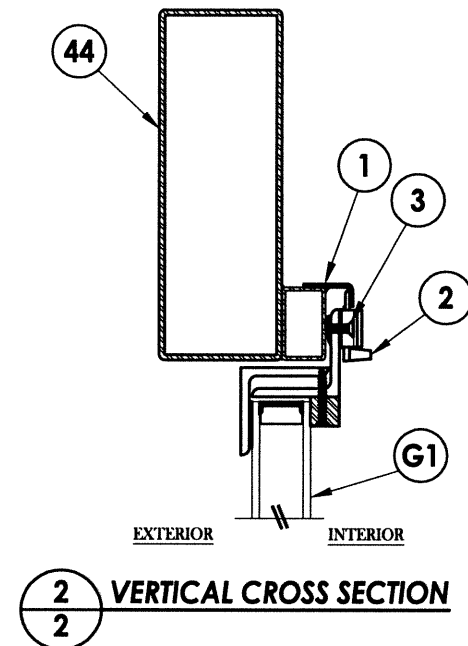

2 VERTICAL CROSS SECTION

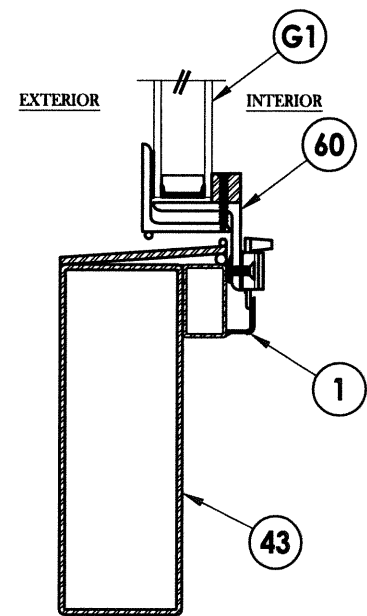

3 VERTICAL CROSS SECTION

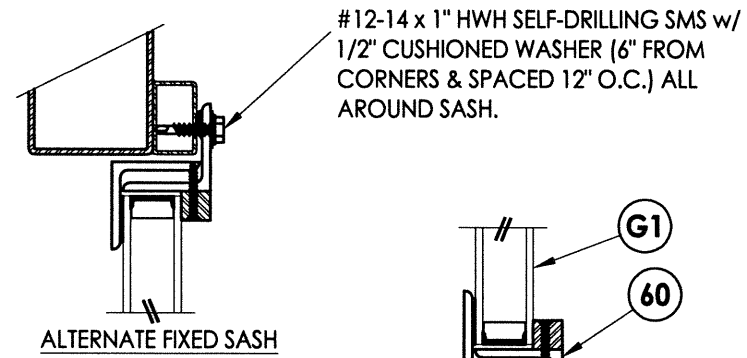

ALTERNATE FIXED SASH

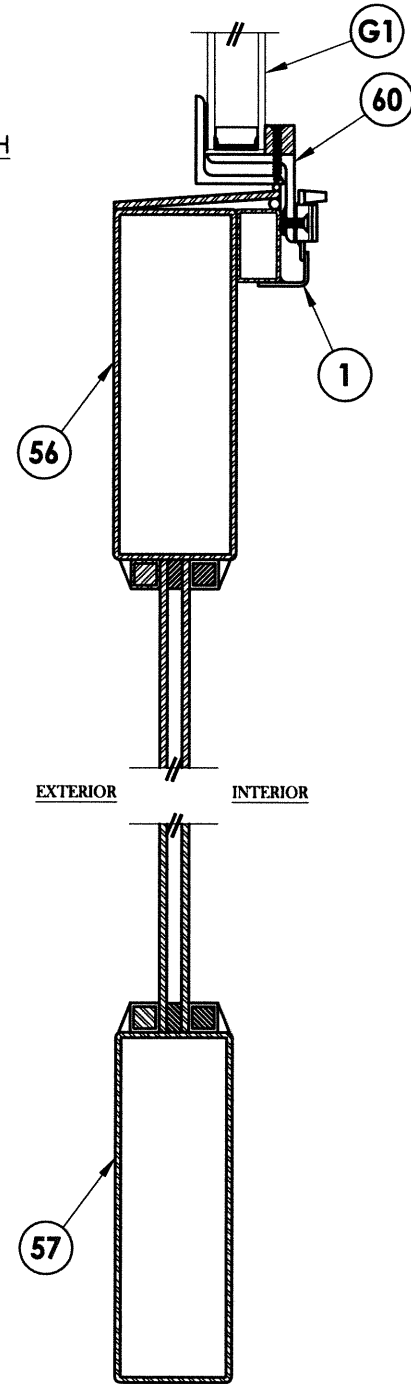

4 VERTICAL CROSS SECTION

Documents Prepared By:

RW BUILDING CONSULTANTS, INC.
P.O. Box 230 Valrico FL 33595
Phone No.: 813.659.9197
Florida Board of Professional Engineers
Certificate Of Authorization No. 9813
1750 12.30.13
Lyndon F. Schmidt, P.E. No. 43409

PRODUCT: CLARK HALL IRON DOORS

PART OR ASSEMBLY: DOOR PANEL DETAILS

NO.	DATE	BY	REVISIONS

DATE: 11/8/13
SCALE: N.T.S.
DWG. BY: JK
CHK. BY: LFS
DRAWING NO.: FL-16663.2
SHEET 2 OF 11

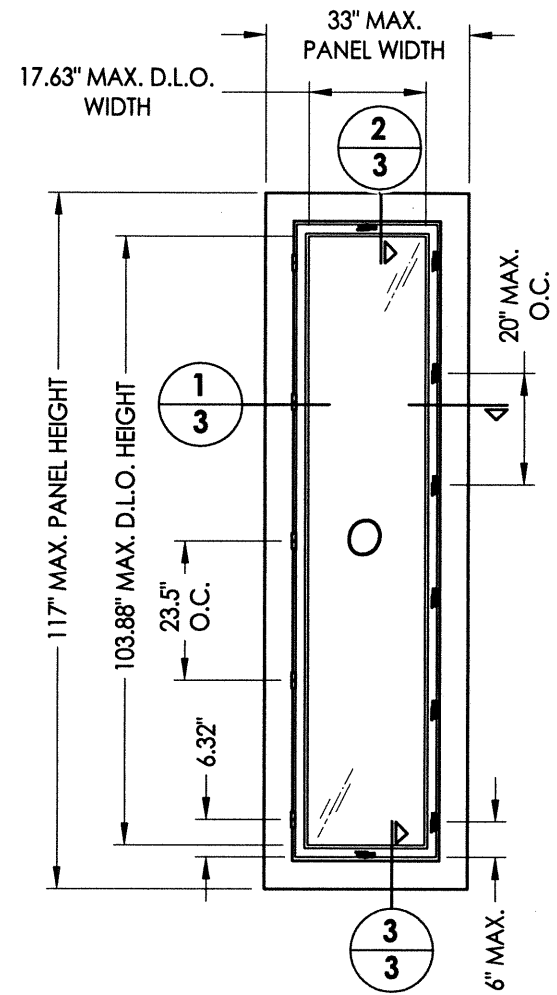

50 SIDELITE PANEL
w/ Operable Sash

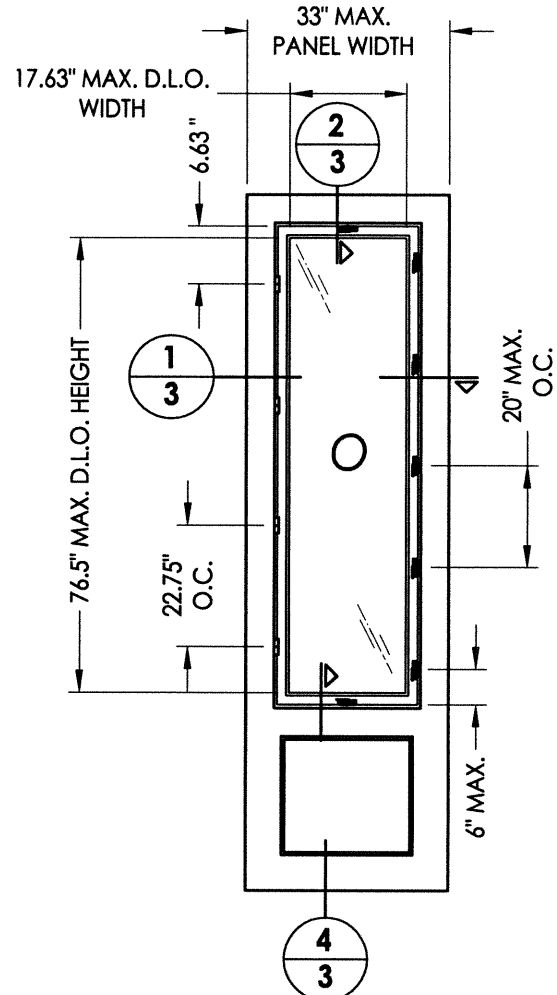

55 3/4 SIDELITE PANEL
w/ Operable Sash & Fixed Panel

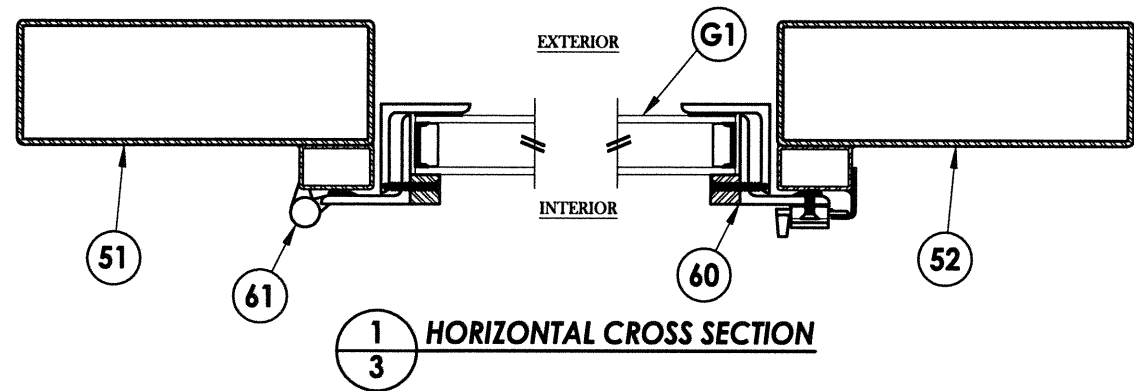

1 HORIZONTAL CROSS SECTION

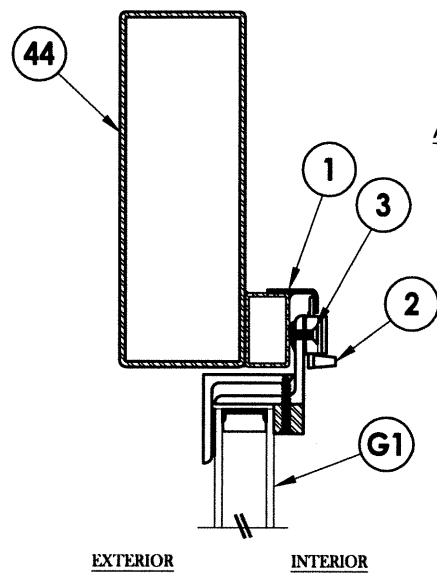

2 VERTICAL CROSS SECTION

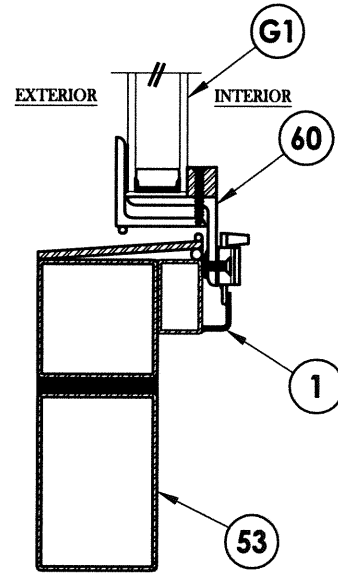

3 VERTICAL CROSS SECTION

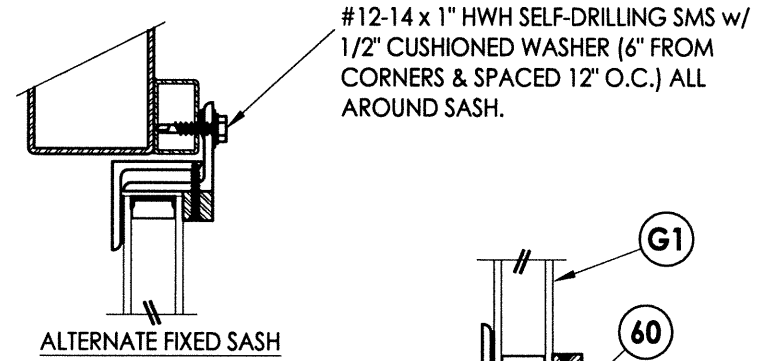

ALTERNATE FIXED SASH

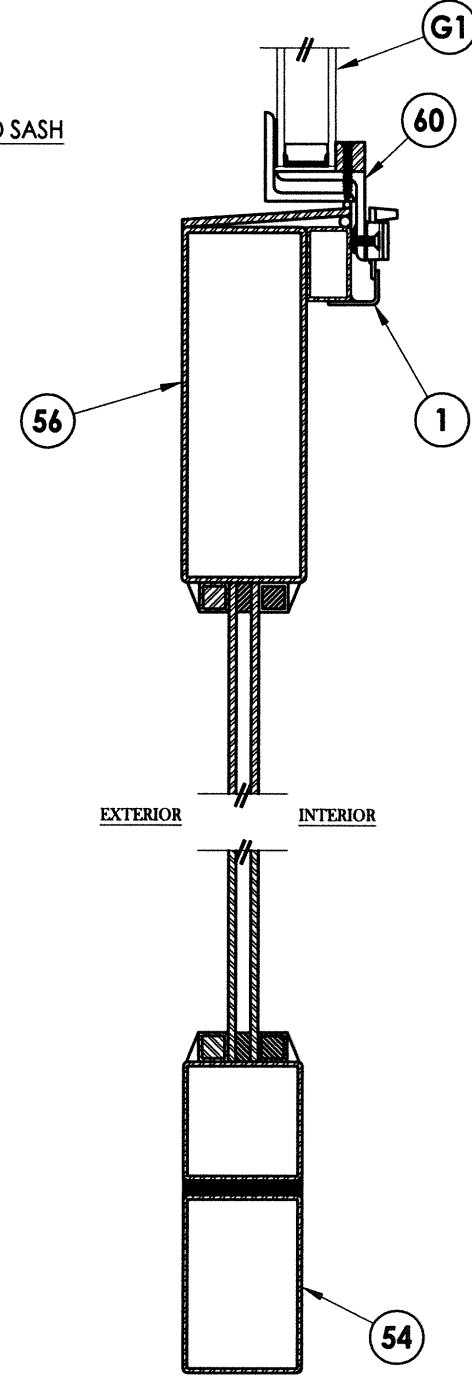

4 VERTICAL CROSS SECTION

Documents Prepared By:

RW BUILDING CONSULTANTS, INC.
P.O. Box 230 Valrico FL, 33595
Phone No.: 813.659.9197
Florida Board of Professional Engineers
Certificate Of Authorization No. 9813
12.30.13
Lyndon F. Schmidt, P.E. No. 43409

PRODUCT: CLARK HALL IRON DOORS

PART OR ASSEMBLY: SIDELITE PANEL DETAILS

NO.	DATE	BY	REVISIONS

DATE: 11/8/13

SCALE: N.T.S.

DWG. BY: JK

CHK. BY: LFS

DRAWING NO.: FL-16663.2

SHEET 3 OF 11

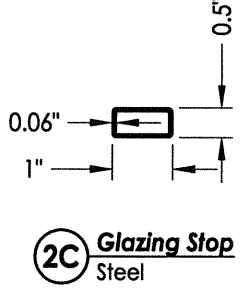
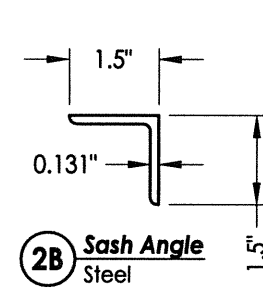
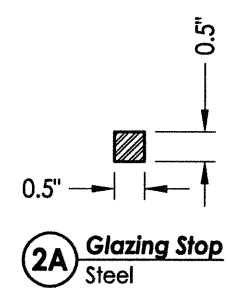
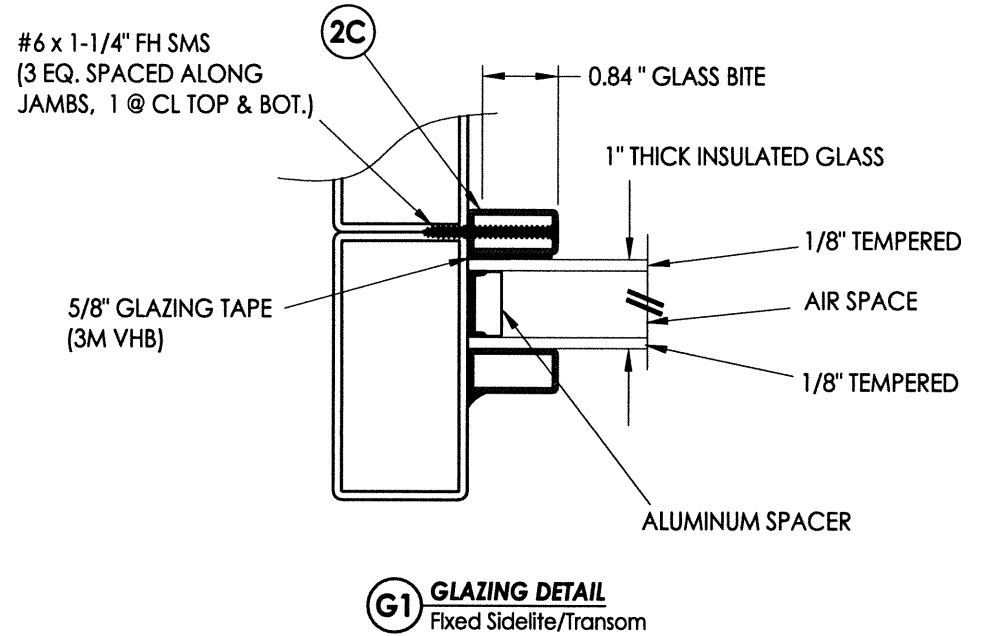
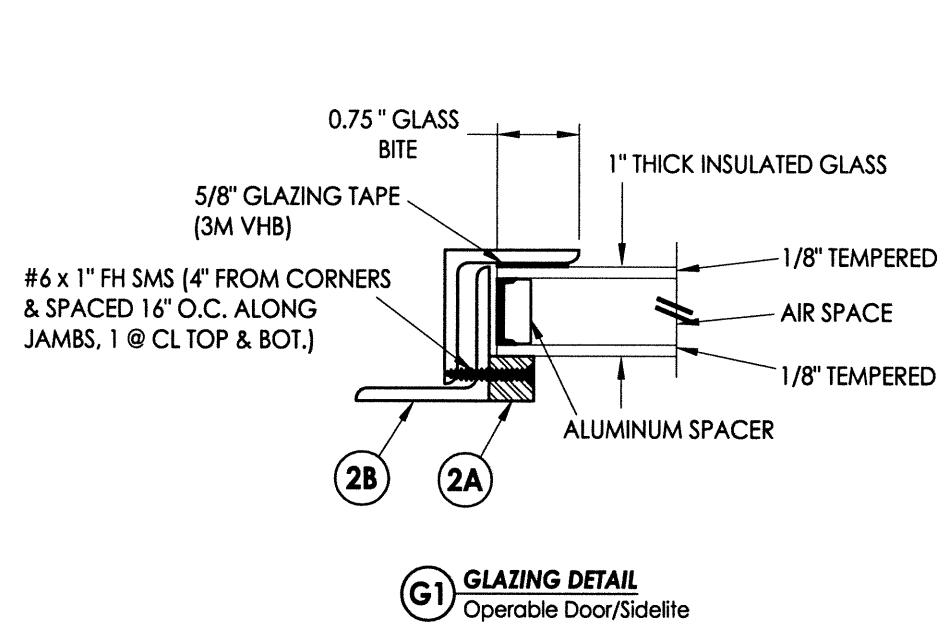

Documents Prepared By: R.W. BUILDING CONSULTANTS, INC. P.O. Box 230 Valrico FL, 33595 Phone No.: 813.659.9197 Florida Board of Professional Engineers Certificate Of Authorization No. 9813 <i>LFS</i> 12-30-13 Lyndon F. Schmidt, P.E. No. 43409	
PRODUCT: CLARK HALL IRON DOORS	PART OR ASSEMBLY: GLAZING DETAILS
NO.	DATE
BY	REVISIONS
DATE: 11/8/13	
SCALE: N.T.S.	
DWG. BY: JK	
CHK. BY: LFS	
DRAWING NO.: FL-16663.2	
SHEET 4 OF 11	

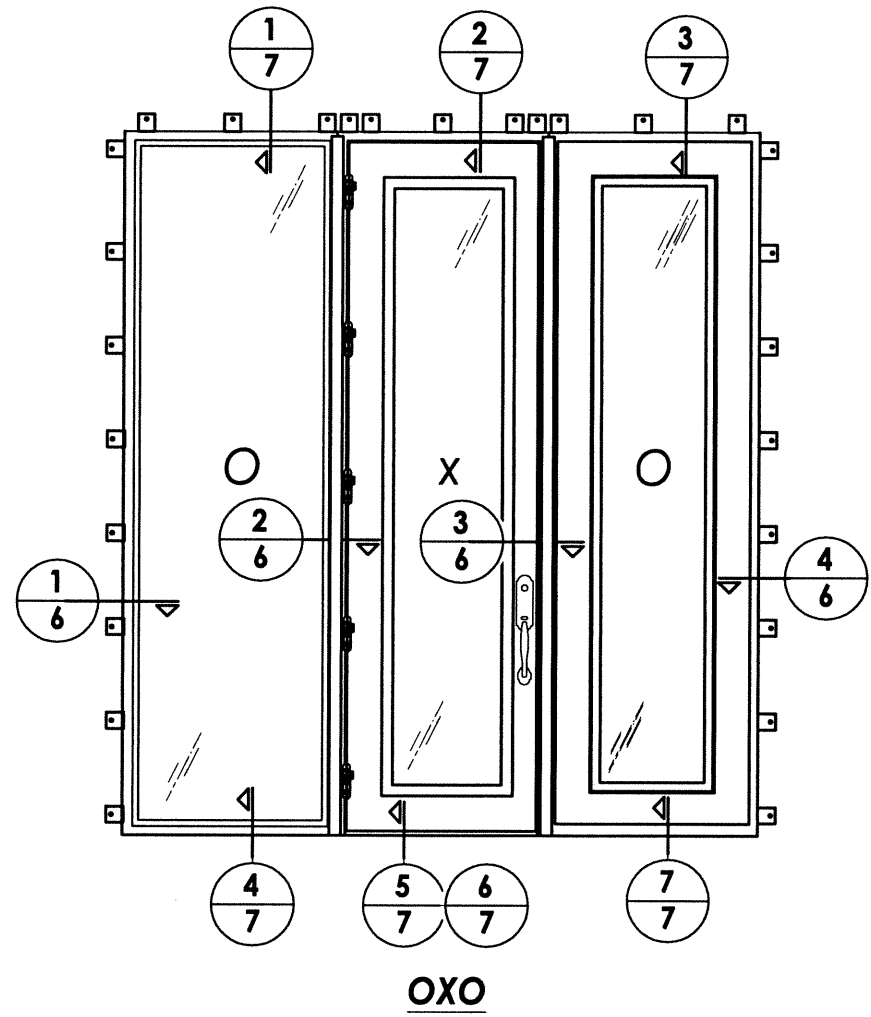

OXO

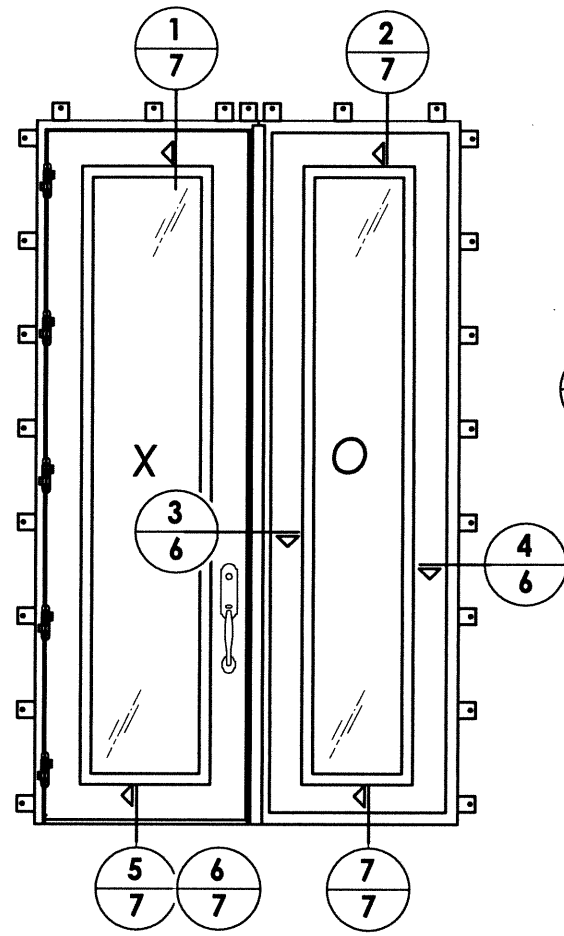

OX/XO

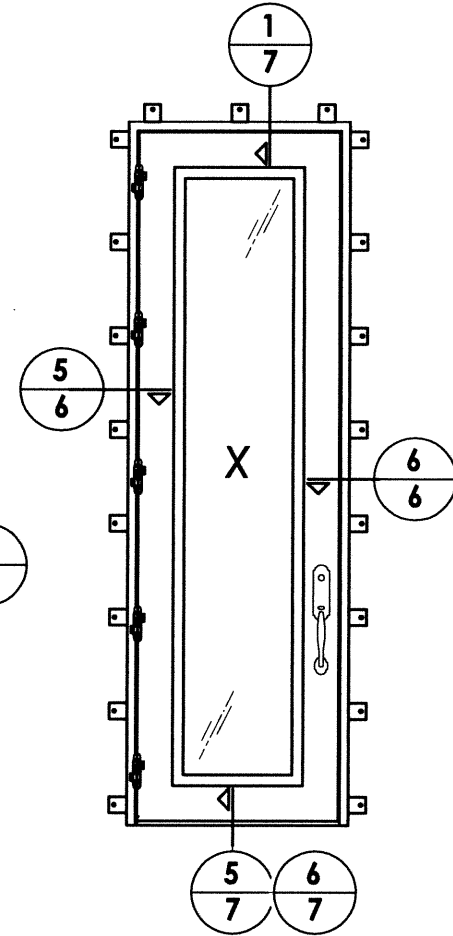

X

LOCK HARDWARE TABLE

MANUFACTURER	MODEL
EMTEK	TUBULAR ENTRY SET (SHERIDAN - 451812)
SUN VALLEY BRONZE ACCURATE LOCK & HARDWARE	LEVER/KNOB ENTRY SET (RIDGE: CS-421PLD) MORTISE LOCK
ASHLEY NORTON	TUBULAR ENTRY SET (SQTUB w/ 900 SERIES KNOB)
ASHLEY NORTON ACCURATE LOCK & HARDWARE	MORTISE LOCK (SQMOR w/ 900 SERIES KNOB) MORTISE LOCK

PRODUCT: CLARK HALL IRON DOORS

PART OR ASSEMBLY: ELEVATIONS

DATE: 10/30/13
 SCALE: N.T.S.
 DWG. BY: JK
 CHK. BY: LFS
 DRAWING NO.: FL-16663.2
 SHEET 5 OF 11

Documents Prepared By:
RW BUILDING CONSULTANTS, INC.
 P.O. Box 230 Valrico FL 33595
 Phone No.: 813.659.9197
 Florida Board of Professional Engineers
 Certificate Of Authorization No. 9813
 LFS 12-30-13
 Lyndon F. Schmidt, P.E. No. 43409

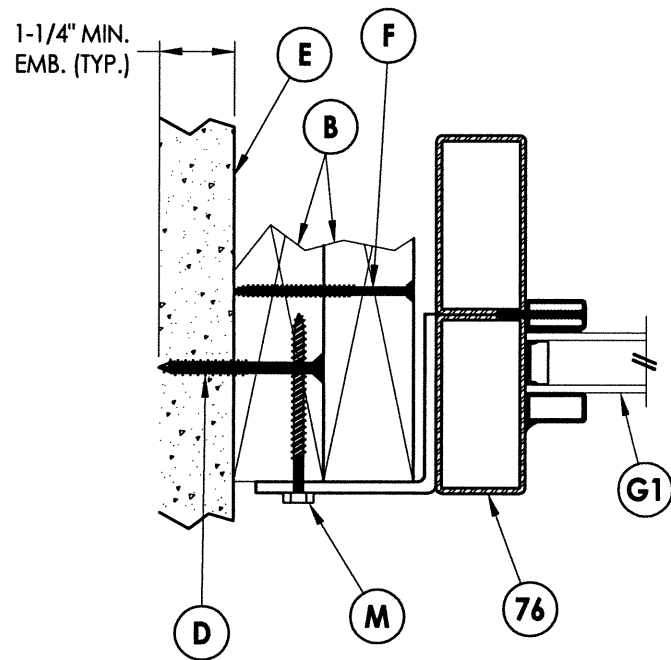

1
6 HORIZONTAL CROSS SECTION

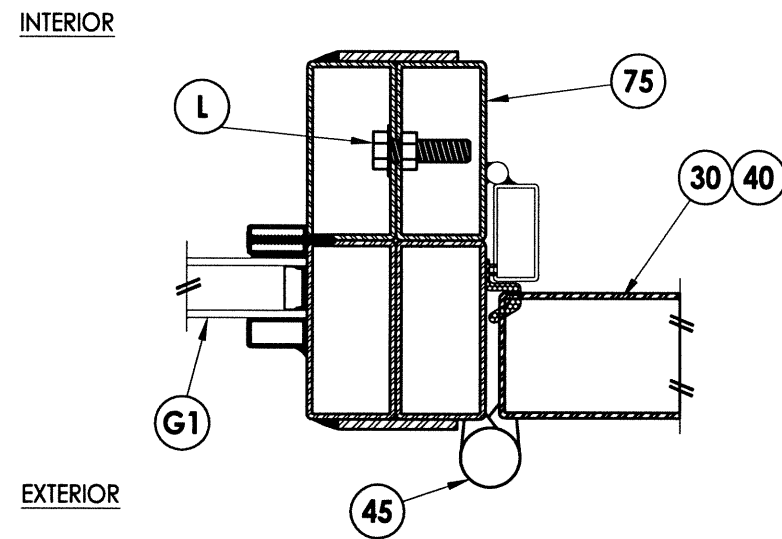

2
6 HORIZONTAL CROSS SECTION
Outswing Shown (Inswing Similar)

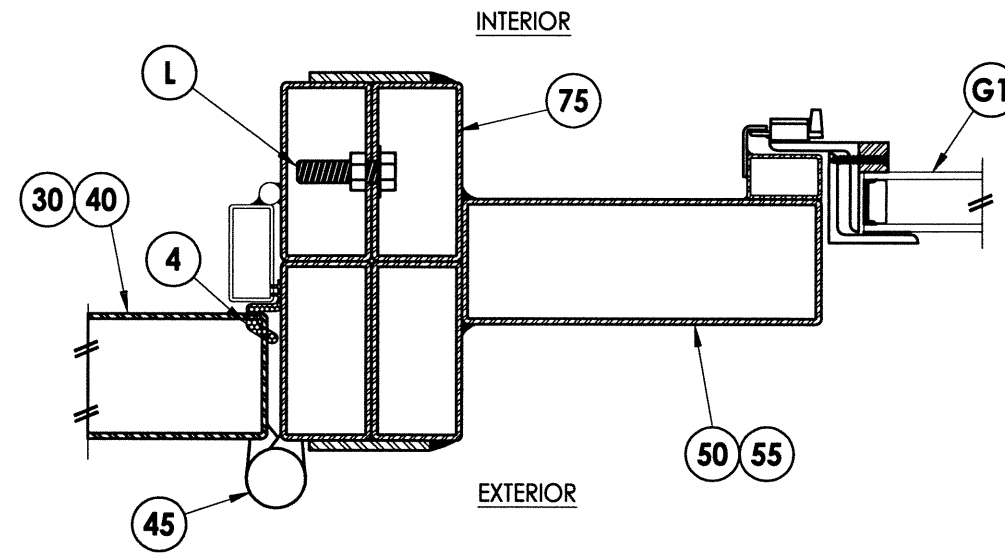

3
6 HORIZONTAL CROSS SECTION
Outswing Shown (Inswing Similar)

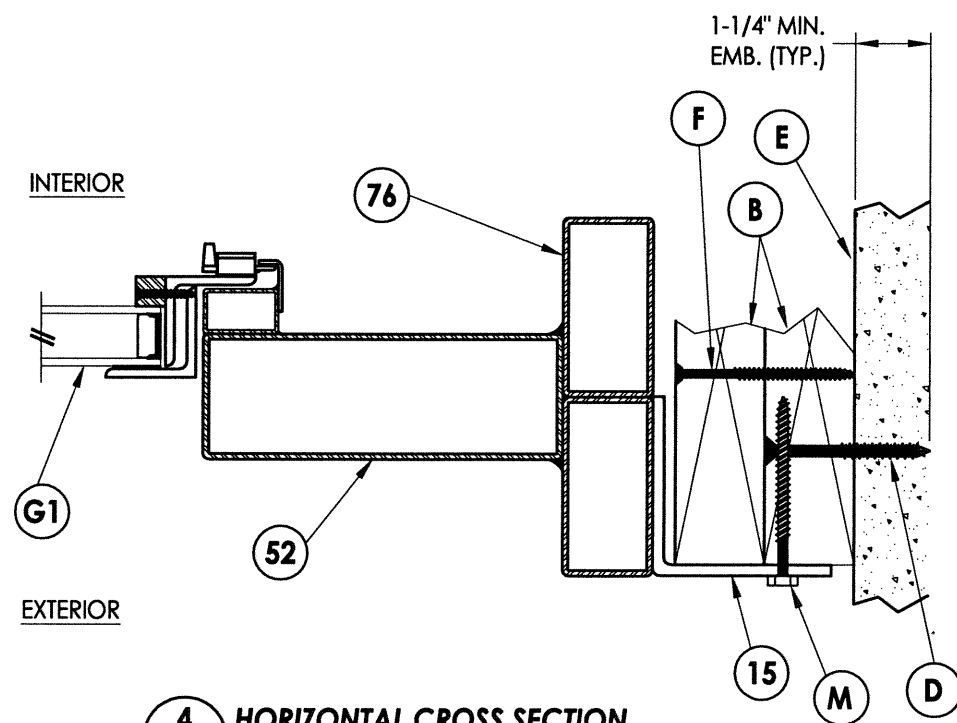

4
6 HORIZONTAL CROSS SECTION
Outswing Shown (Inswing Similar)

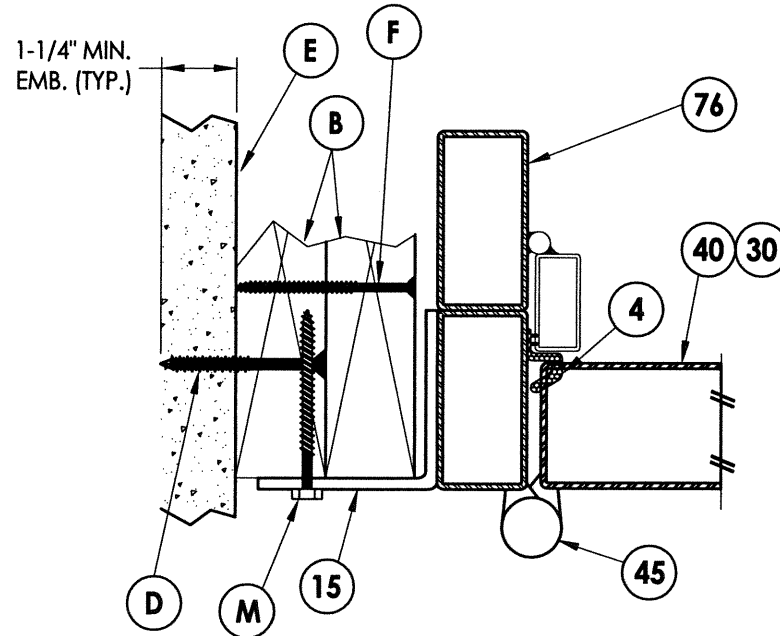

5
6 HORIZONTAL CROSS SECTION
Outswing Shown (Inswing Similar)

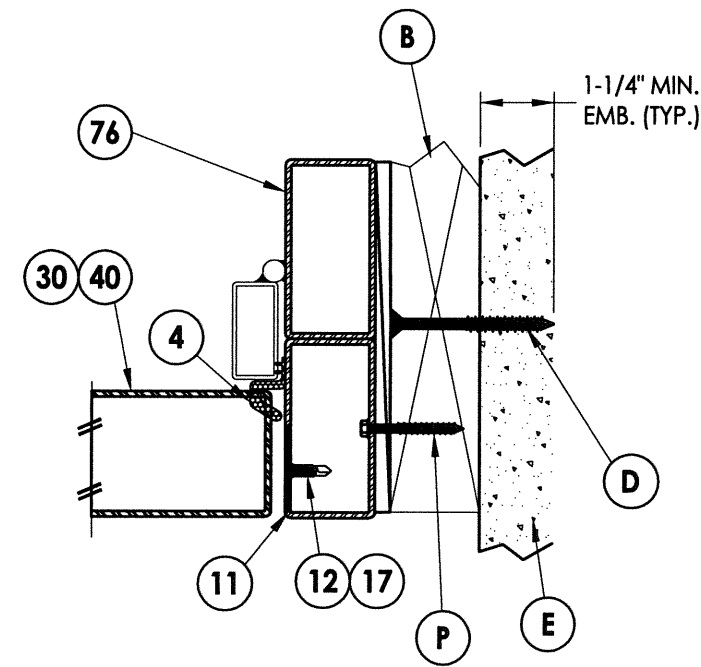

6
6 HORIZONTAL CROSS SECTION
Shown w/ Optional Through the Frame Anchoring

Documents Prepared By:
RW BUILDING CONSULTANTS, INC.
P.O. Box 230 Vero Beach, FL 33595
Phone No.: 813.659.9197
Florida Board of Professional Engineers
Certificate Of Authorization No. 9813
LFS 12-30-13
Lyndon F. Schmidt, P.E. No. 43409

PRODUCT: CLARK HALL IRON DOORS
PART OR ASSEMBLY: HORIZONTAL CROSS SECTIONS

NO.	DATE	BY

DATE: 10/30/13
SCALE: N.T.S.
DWG. BY: JK
CHK. BY: LFS
DRAWING NO.: FL-16663.2
SHEET 6 OF 11

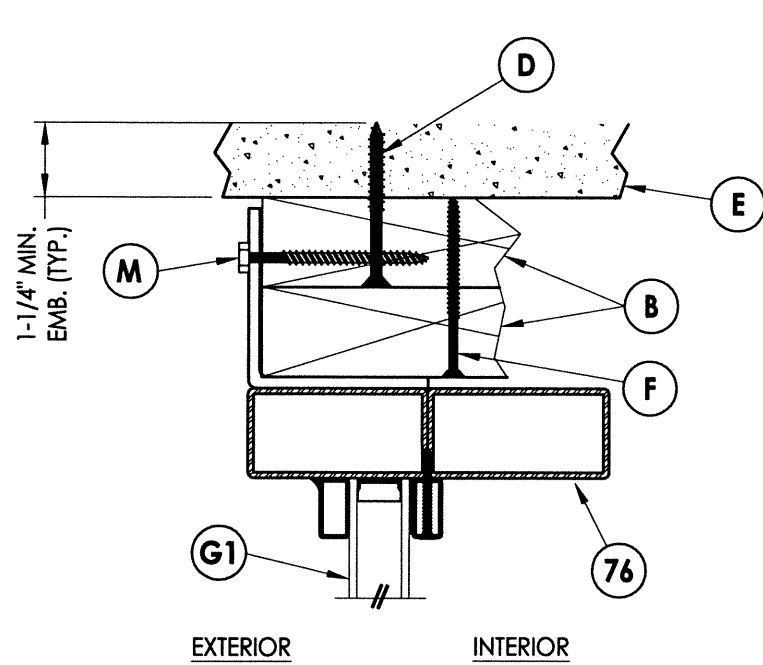

1
7 **VERTICAL CROSS SECTION**
Outswing Shown (Inswing Similar)

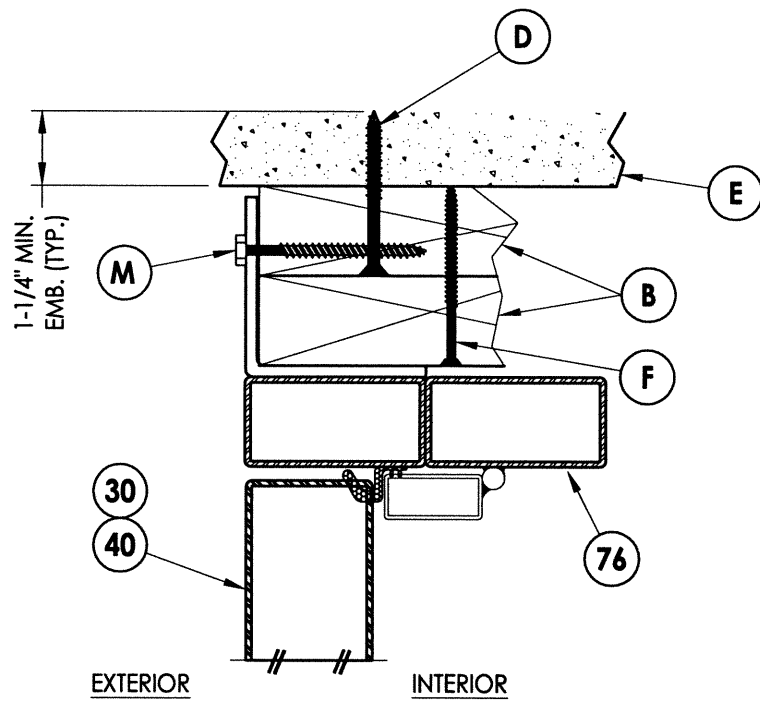

2
7 **VERTICAL CROSS SECTION**
Outswing Shown (Inswing Similar)

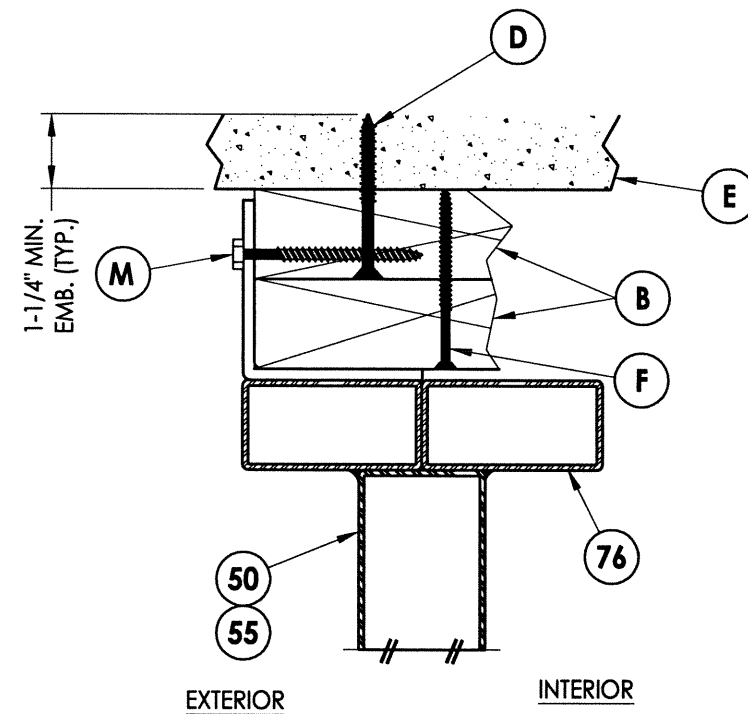

3
7 **VERTICAL CROSS SECTION**
Outswing Shown (Inswing Similar)

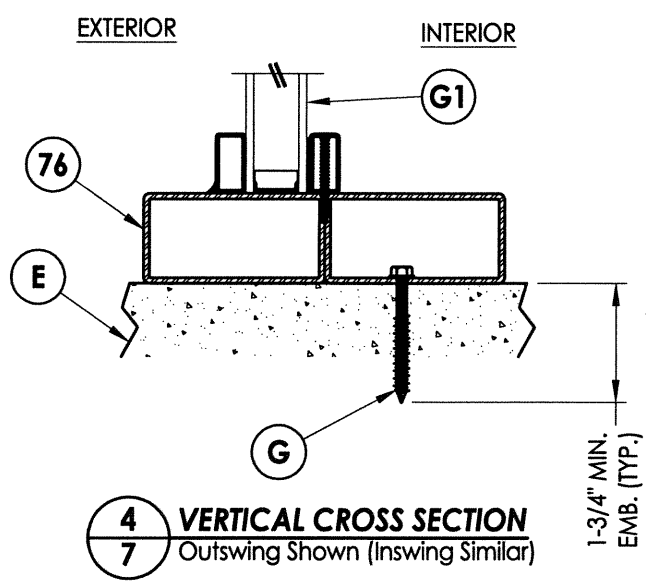

4
7 **VERTICAL CROSS SECTION**
Outswing Shown (Inswing Similar)

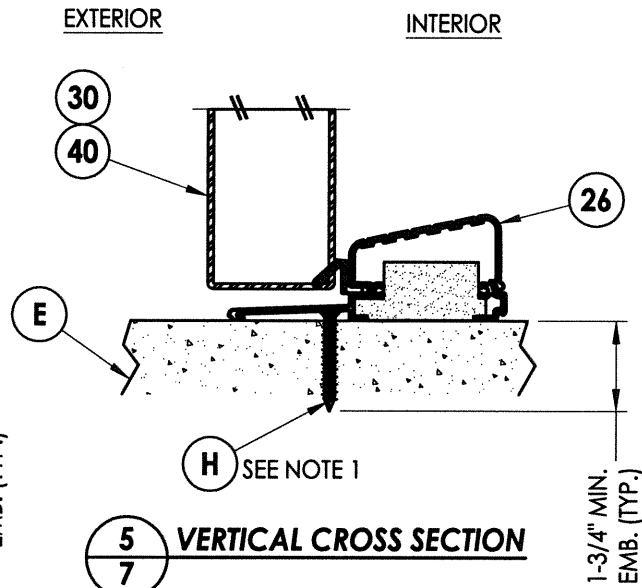

5
7 **VERTICAL CROSS SECTION**

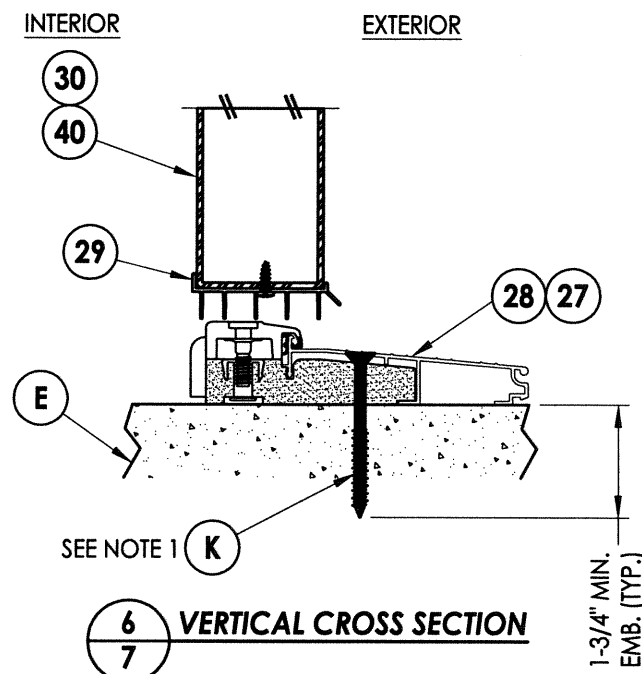

6
7 **VERTICAL CROSS SECTION**

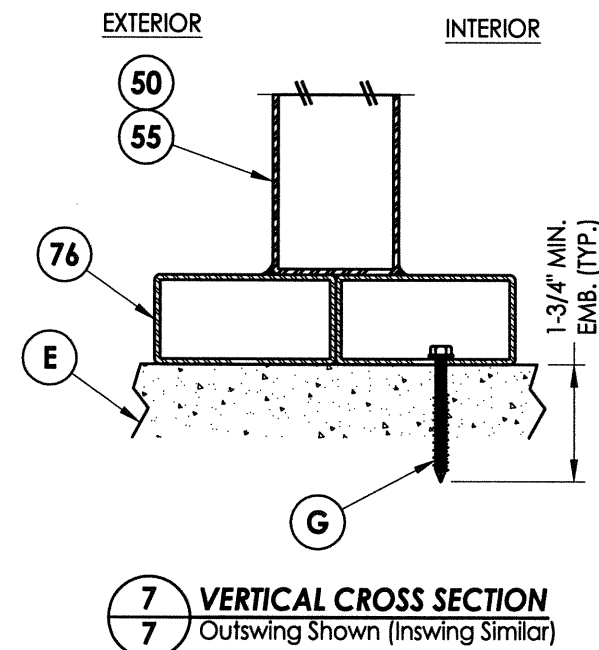

7
7 **VERTICAL CROSS SECTION**
Outswing Shown (Inswing Similar)

NOTE:
1. Sill anchor is not required for Single Door (X).

Documents Prepared By:
RW BUILDING CONSULTANTS, INC.
P.O. Box 230 Valrico FL 33595
Phone No.: 813.659.9197
Florida Board of Professional Engineers
Certificate of Authorization No. 9813
LF 12-30-13
Lyndon F. Schmidt, P.E. No. 43409

PRODUCT: CLARK HALL IRON DOORS
PART OR ASSEMBLY: VERTICAL CROSS SECTIONS

NO.	DATE	BY

DATE: 10/30/13
SCALE: N.T.S.
DWG. BY: JK
CHK. BY: LFS
DRAWING NO.: FL-16663.2
SHEET 7 OF 11

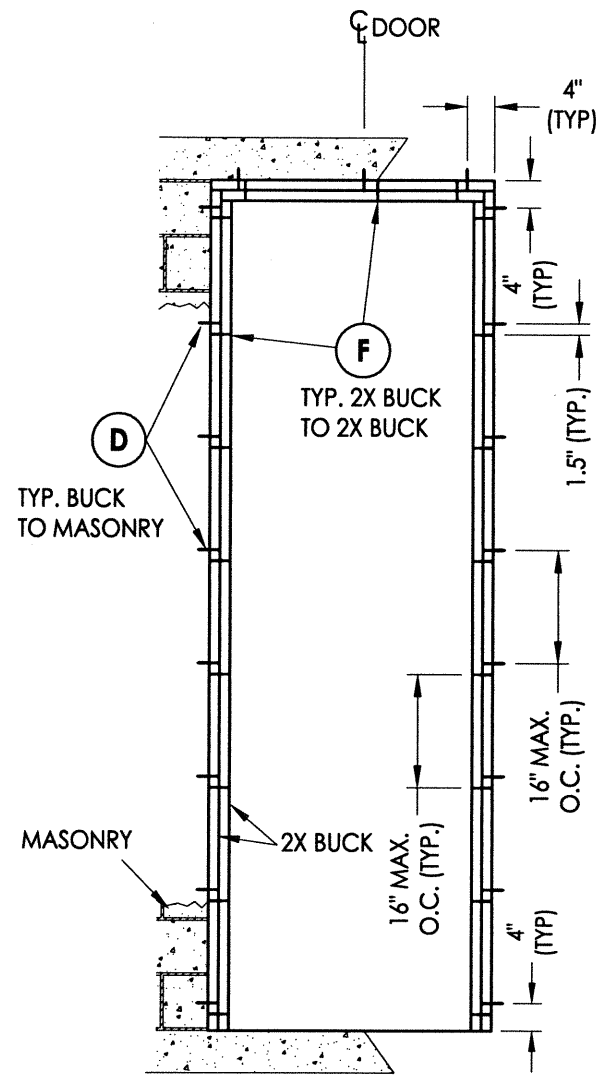

BUCK ANCHORING
X

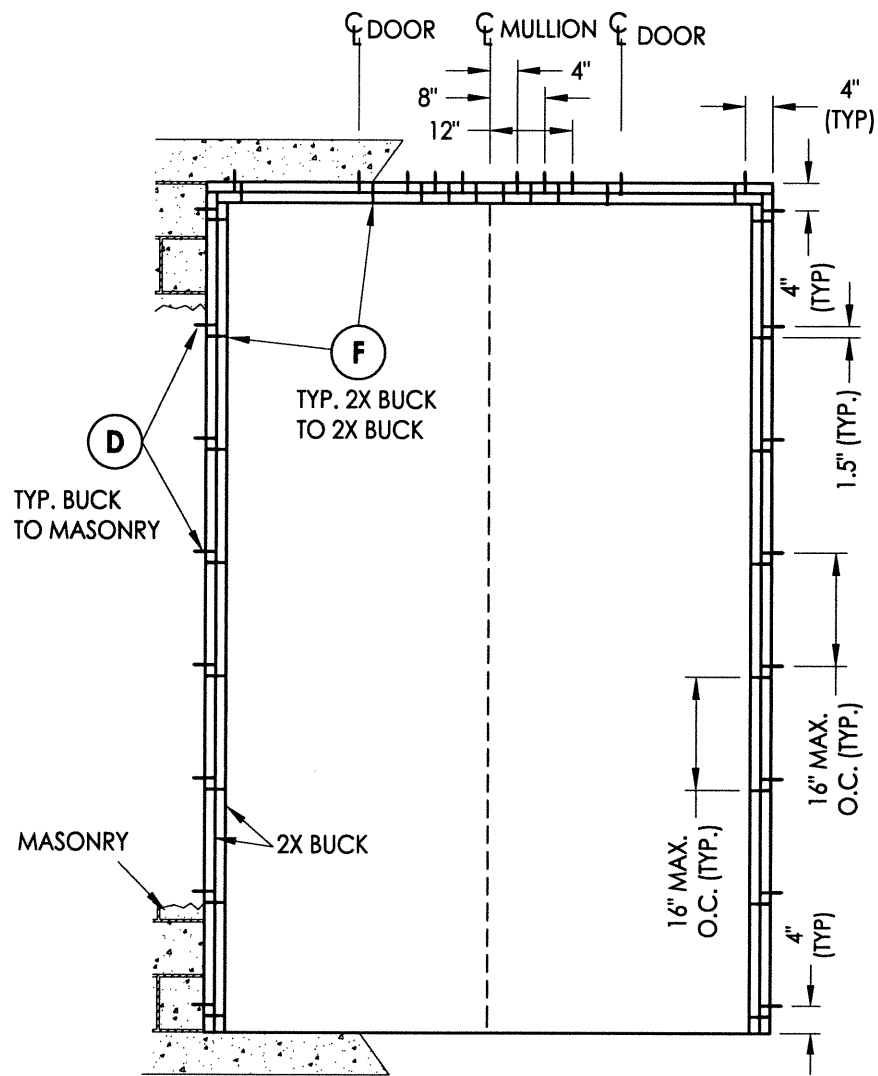

BUCK ANCHORING
OX or XO

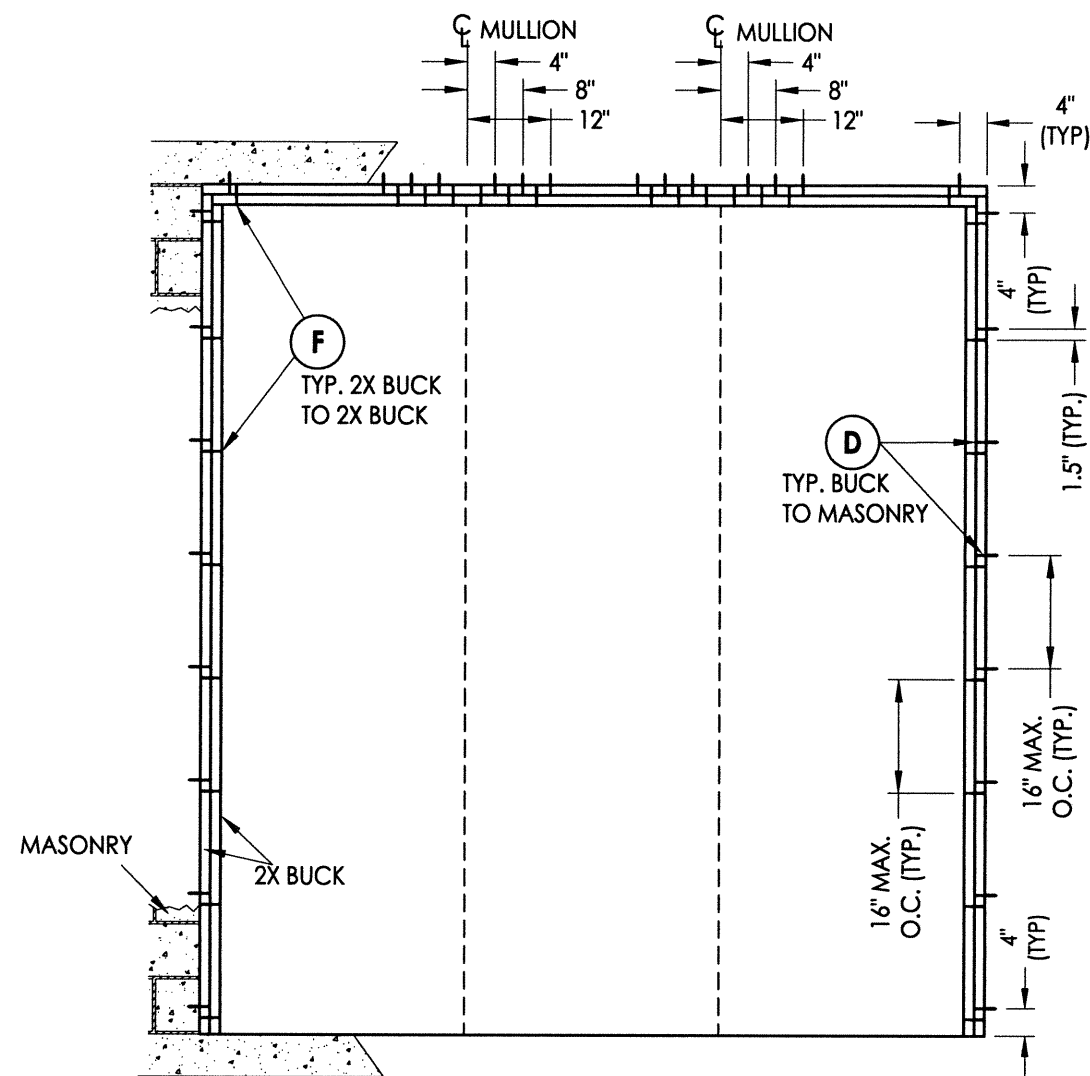

BUCK ANCHORING
OXO

CONCRETE ANCHOR NOTES:

1. Concrete anchor locations at the corners may be adjusted to maintain the min. edge distance to mortar joints.
2. Concrete anchor locations noted as "MAX. ON CENTER" must be adjusted to maintain the min. edge distance to mortar joints, additional concrete anchors may be required to ensure the "MAX. ON CENTER" dimension are not exceeded.
3. Concrete anchor table:

ANCHOR TYPE	ANCHOR SIZE	MIN. EMBEDMENT	MIN. CLEARANCE TO MASONRY EDGE	MIN. CLEARANCE TO ADJACENT ANCHOR
ITW TAPCON®	1/4"	1-1/4"	2-1/2"	4"
ELCO ULTRACON®	1/4"	1-1/4"	2-1/2"	4"

NOTE FOR THROUGH THE FRAME ANCHORING ONLY ONE 2X BUCK IS REQUIRED, ANCHORED AS SHOWN.

Documents Prepared By:

RW BUILDING CONSULTANTS, INC.
P.O. Box 230 Valrico FL 33595
Phone No.: 813.659.9197

Florida Board of Professional Engineers
Certificate Of Authorization No. 9813

12.30.13
Lyndon F. Schmidt, P.E. No. 43409

PRODUCT: CLARK HALL IRON DOORS

PART OR ASSEMBLY: BUCK ANCHORING

NO.	DATE	BY

DATE: 10/30/13

SCALE: N.T.S.

DWG. BY: JK

CHK. BY: LFS

DRAWING NO.:

FL-16663.2

SHEET 8 OF 11

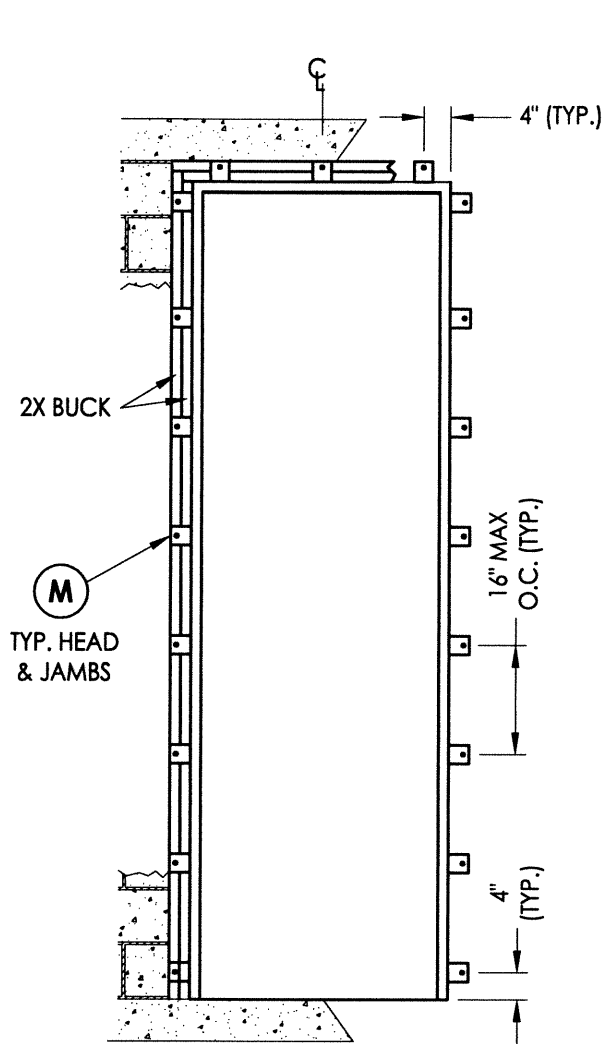

FRAME ANCHORING
X

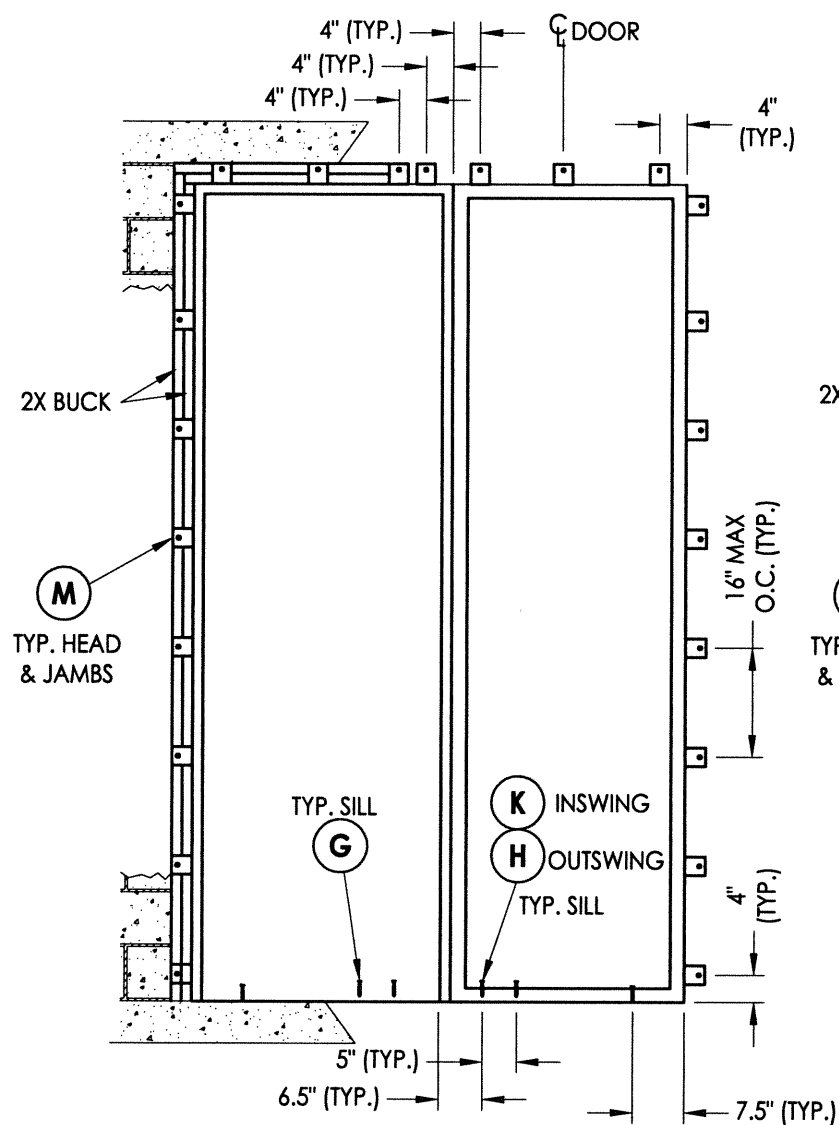

FRAME ANCHORING
XX

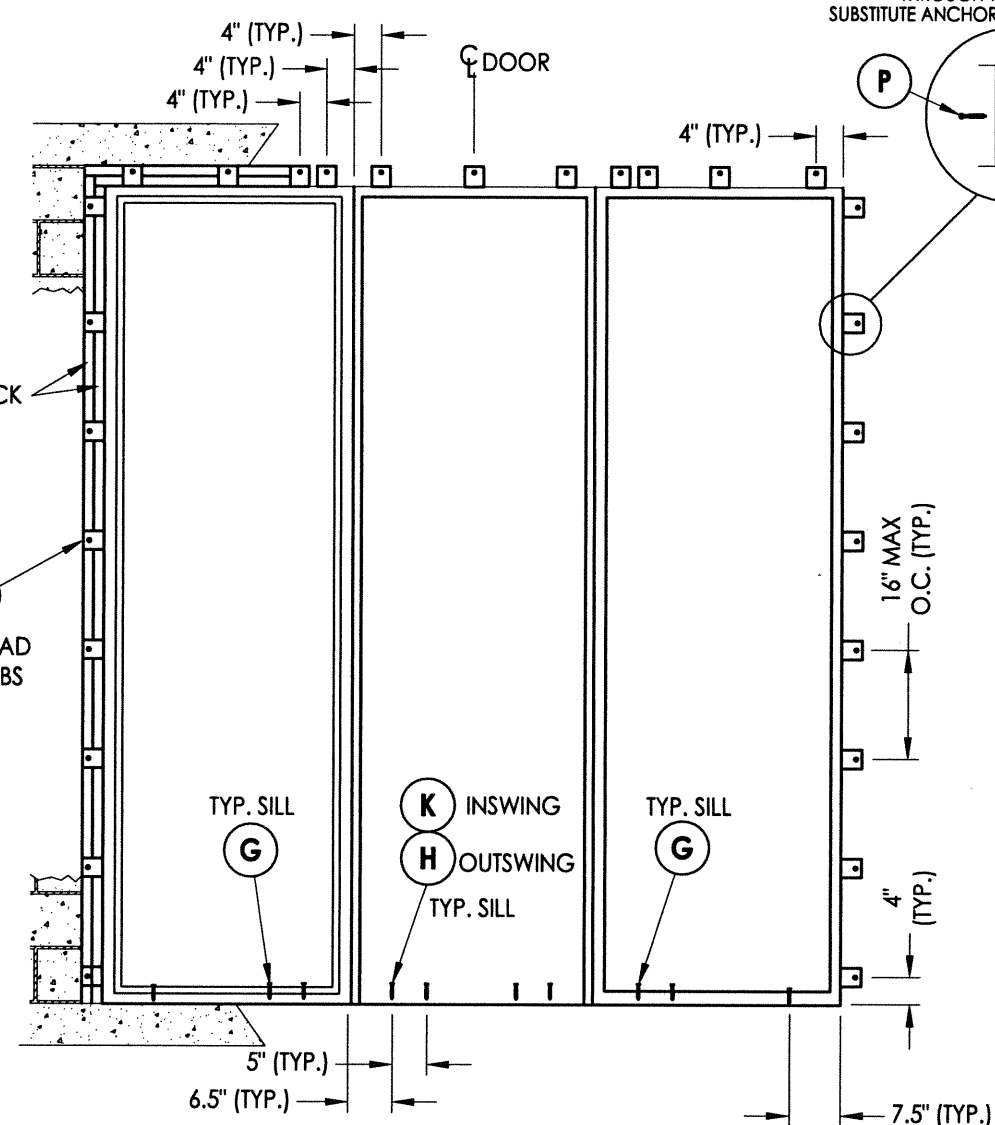

FRAME ANCHORING
OXO

ALTERNATE ANCHORING
THROUGH THE FRAME
SUBSTITUTE ANCHOR @ EACH BRACKET

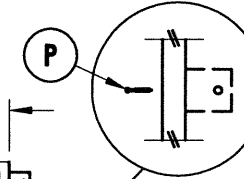

CONCRETE ANCHOR NOTES:

- Concrete anchor locations at the corners may be adjusted to maintain the min. edge distance to mortar joints.
- Concrete anchor locations noted as "MAX. ON CENTER" must be adjusted to maintain the min. edge distance to mortar joints, additional concrete anchors may be required to ensure the "MAX. ON CENTER" dimension are not exceeded.
- Concrete anchor table:

ANCHOR TYPE	ANCHOR SIZE	MIN. EMBEDMENT	MIN. CLEARANCE TO MASONRY EDGE	MIN. CLEARANCE TO ADJACENT ANCHOR
ITW TAPCON®	3/16"	1-1/4"	3"	2-1/2"
	1/4"	1-1/4"	2-1/2"	4"
	5/16" (XL)	1-3/4"	2-1/2"	5"
ELCO ULTRACON®	1/4"	1-1/4"	2-1/2"	4"
	5/16"	1-3/4"	2-1/2"	5"

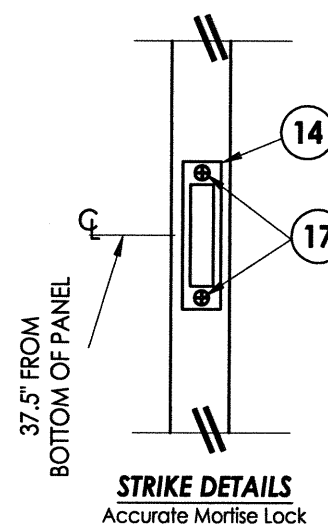
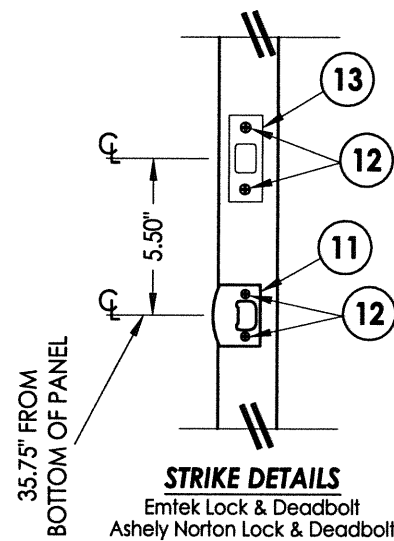

Documents Prepared By:
RW BUILDING CONSULTANTS, INC.
P.O. Box 230 Valrico FL, 33595
Phone No.: 813.659.9197
Florida Board of Professional Engineers
Certificate Of Authorization No. 9813
7/20/12-30-13
Lyndon F. Schmidt, P.E. No. 43409

PRODUCT:	PART OR ASSEMBLY:	REVISIONS
CLARK HALL IRON DOORS	FRAME ANCHORING	
		NO. DATE BY

DATE: 10/30/13
SCALE: N.T.S.
DWG. BY: JK
CHK. BY: LFS
DRAWING NO.: FL-16663.2
SHEET 9 OF 11

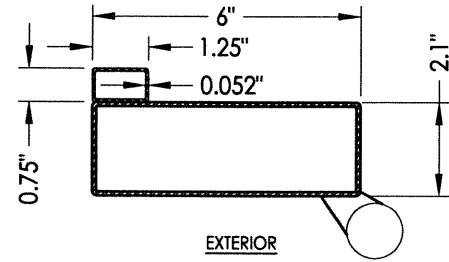

31 Full Lite Door Panel
Active Hinge Stile

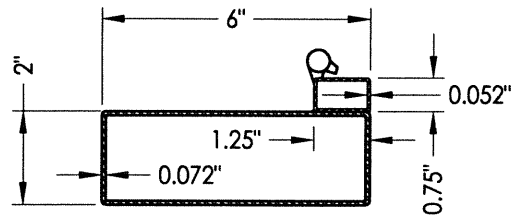

51 Sidelite Panel
Operable Sash Hinge Stile

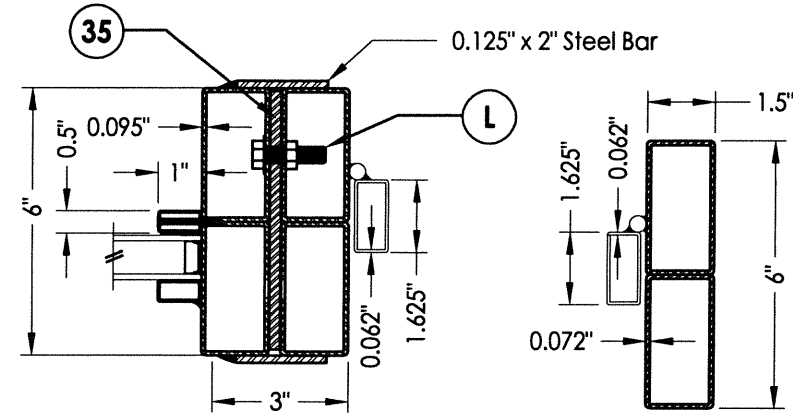

75 MULLION
Vertical with Direct Set Sidelite shown
(Horizontal Mullion Similar)

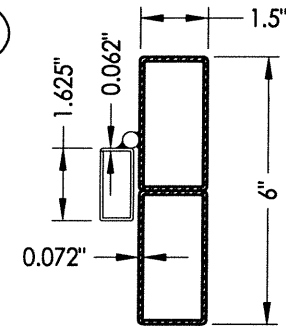

76 Jamb

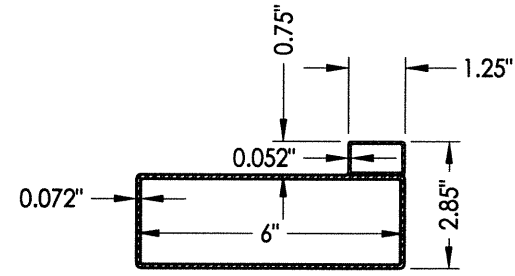

32 Full Lite Door Panel
Active Latch Stile

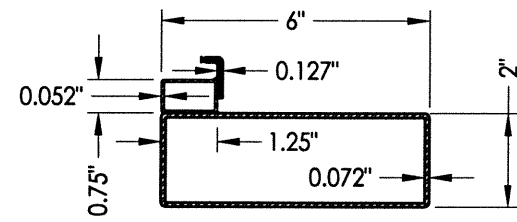

52 Sidelite Panel
Operable Sash Latch Stile

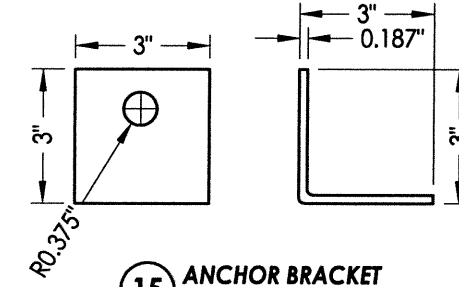

15 ANCHOR BRACKET

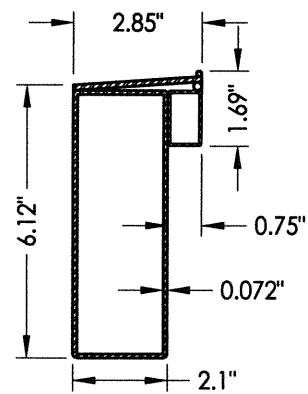

43 Full Lite Door Panel
Bottom Rail

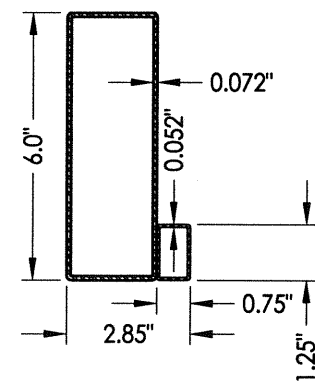

44 Full Lite Door Panel
Top Rail

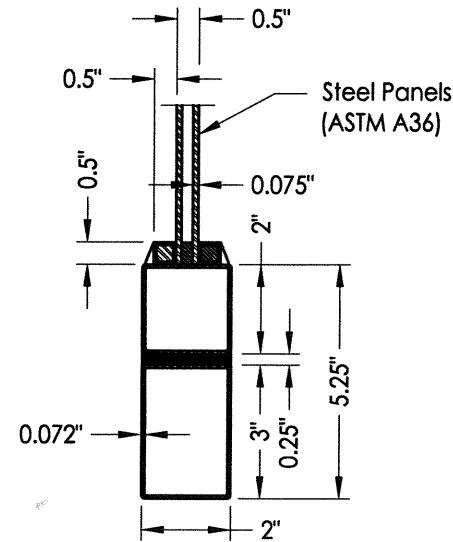

54 Bottom Rail
3/4 Lite Sidelite Panel

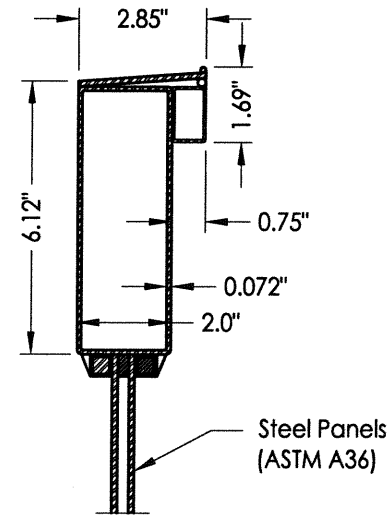

56 Mid Rail
3/4 Lite Sidelite Panel

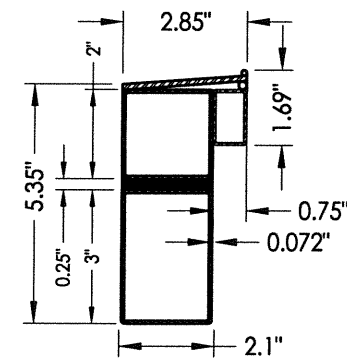

53 Bottom Rail
Sidelite Panel

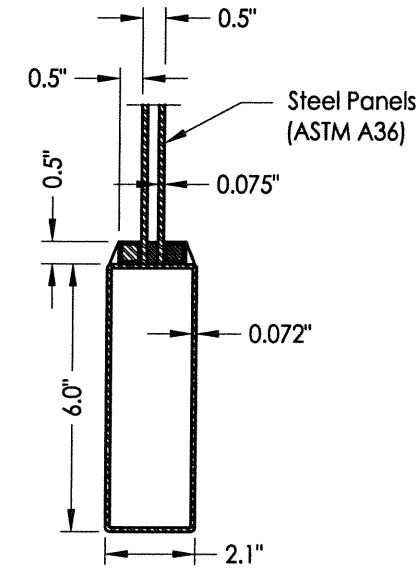

57 Bottom Rail
3/4 Lite Door Panel

Documents Prepared By:
RW BUILDING CONSULTANTS, INC.
P.O. Box 230 Vairico FL. 33595
Phone No.: 813.659.9197
Florida Board of Professional Engineers
Certificate Of Authorization No. 9813
Lyndon F. Schmidt, P.E. No. 43409

PRODUCT: CLARK HALL IRON DOORS
PART OR ASSEMBLY: COMPONENTS

NO.	DATE	BY

DATE: 10/30/13
SCALE: N.T.S.
DWG. BY: JK
CHK. BY: LFS
DRAWING NO.: FL-16663.2
SHEET 10 OF 11

BILL OF MATERIALS		
ITEM #	DESCRIPTION	MATERIAL
B	2X BUCK SG >= 0.55	WOOD
D	1/4" X 2-3/4" PFH ELCO OR ITW CONCRETE SCREW	STEEL
E	MASONRY - 3,000 PSI MIN. CONCRETE CONFORMING TO ACI301 OR HOLLOW BLOCK CONFORMING TO ASTM C90	CONCRETE
F	#10 X 3" PFH WOOD SCREW	STEEL
G	5/16" X 2-1/4" HH ELCO OR ITW CONCRETE SCREW	STEEL
H	5/16" X 2-1/4" PFH ELCO OR ITW CONCRETE SCREW	STEEL
J	3/16" X 2-1/4" PFH ITW CONCRETE SCREW	STEEL
K	5/16" X 2-3/4" PFH ELCO OR ITW CONCRETE SCREW	STEEL
L	5/16-18 X 1-1/2" HH BOLT (GR. 5) w/ LOCK WASHER & NUT	STEEL
M	3/8" X 3" HH LAG SCREW	STEEL
P	#12 X 1-1/2" HWH SMS	STEEL
1	SASH LATCH STRIKE	STEEL
2	SASH LATCH	STEEL
3	#8 X 1/4" PFH SMS	STEEL
4	WEATHERSTRIP (QLON)	FOAM
11	LATCH STRIKE PLATE	STEEL
12	#8 X 3/4" PFH SMS	STEEL
13	DEADBOLT STRIKE PLATE	STEEL
14	MORTISE STRIKE PLATE	STEEL
15	ANCHORING BRACKET	STEEL
17	#12-24 X 13/16" PFH COMBINATION WOOD/MACHINE SCREW	STEEL
20	FLIP BOLT	STEEL
25	#6 X 1/2" PWH SELF TAPPING SMS	STEEL
26	OUTSWING THRESHOLD (DLP)	ALUM/COMP
27	ADA THRESHOLD	ALUM
28	INSWING THRESHOLD (AFCO)	ALUM/COMP
29	DOOR SWEEP (w/ #8 x 3/4" SMS)	-
30	DOOR PANEL (FULL LITE)	-
31	HINGE STILE (ACTIVE DOOR)	ASTM A36 STEEL
32	LATCH STILE (ACTIVE DOOR)	ASTM A36 STEEL
35	MULLION REINFORCEMENT	ASTM A36 STEEL
40	DOOR PANEL (3/4 LITE)	-
43	BOTTOM RAIL (FULL LITE)	ASTM A36 STEEL
44	TOP RAIL (FULL LITE)	ASTM A36 STEEL
45	DOOR PANEL HINGE	STEEL
50	SIDELITE PANEL W/ OPERABLE SASH	-
51	SIDELITE HINGE STILE	ASTM A36 STEEL
52	SIDELITE LATCH STILE	ASTM A36 STEEL
53	BOTTOM RAIL (SIDELITE PANEL)	ASTM A36 STEEL
54	BOTTOM RAIL (3/4 LITE SIDELITE PANEL)	ASTM A36 STEEL
55	3/4 SIDELITE PANEL W/ OPERABLE SASH	-
56	MID RAIL (3/4 LITE SIDELITE PANEL)	ASTM A36 STEEL
57	BOTTOM RAIL (3/4 LITE SIDELITE PANEL)	ASTM A36 STEEL
60	SASH LITE FRAME	STEEL
61	SASH HINGE	STEEL
75	VERTICAL MULL	ASTM A36 STEEL
76	JAMB	ASTM A36 STEEL

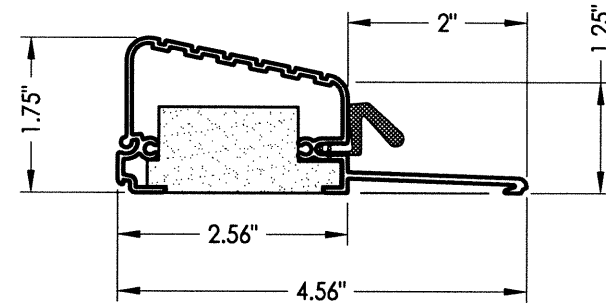

26 OUTSWING THRESHOLD
DLP

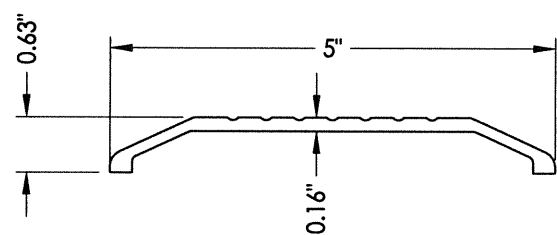

27 ADA THRESHOLD

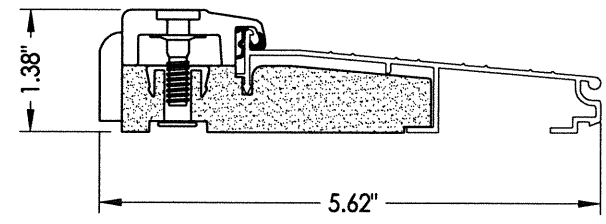

28 INSWING THRESHOLD
AFCO

Documents Prepared By:
RW BUILDING CONSULTANTS, INC.
 P.O. Box 230 Valrico FL 33595
 Phone No.: 813.659.9197
 Florida Board of Professional Engineers
 Certificate Of Authorization No. 9813
LFS 12-30-13
 Lyndon F. Schmidt, P.E. No. 43409

PRODUCT: CLARK HALL IRON DOORS
 PART OR ASSEMBLY: BILL OF MATERIALS & COMPONENTS

NO.	DATE	BY	REVISIONS

DATE: 10/30/13
 SCALE: N.T.S.
 DWG. BY: JK
 CHK. BY: LFS
 DRAWING NO.: FL-16663.2
 SHEET 11 OF 11